

Thermostatic Control Valve

Model R

Typical applications

- Refrigeration compressors
- Industrial compressors
- Turbines
- Engines
- Gear boxes
- High pressure applications



Model R

Key benefits

- No leak design
 - No external moving parts
 - No external dynamic seals
- Easily removable elements
- Environmentally friendly
- Reliable performance
- Easy installation
 - Operates in any mounting position

Key features

- Flow rates of 3 - 82 m³/hr (13 - 360 US gpm)
- DN20 - DN80 (¾" - 3") pipe sizes
- Welded connections
- Tamper-proof temperature settings from 35°C - 82°C (95°F - 180°F)
- Pressure ratings up to 35 bar (500 psi)

Accreditations available

- PED Suitable for Group 1 & 2 liquids (Ensure materials are compatible)
- ATEX  II 2G TX X
- CE Complies with all relevant EU directives

Thermostatic Control Valve - Model R

Contents

Overview	3
Applications	4
Valve Characteristics	4
Pressure drop	4
Flow coefficient	5
Viscosity correction	6
Viscosity correction curve	6
SAE oils viscosities	6
Available versions	7
Temperature and element characteristics	7
Element type and seal material	7
How to Order	8
Specification	9
Weights	9
Valve Dimensions	10
Maintenance and Service Parts	11
Ordering from Americas and Canada	11
Service kits	11
Service kit model number structure	11
Ordering from Europe and Asia-PAC	11
Seal kits	11
Element(s)	11
Seal kit model number structure	12
Element part number structure	12
Service parts	13
Contact	14

Thermostatic Control Valve - Model R

Overview

AMOT Model R thermostatic valves provide reliable control of fluid temperatures in cooling systems, heat recovery and many other temperature control applications.

They are also suitable for process control and industrial applications where fluids must be mixed or diverted depending upon temperature.

All AMOT internally sensed valves have positive 3-way action. This ensures that on process start up all of the flow is through the bypass line giving the fastest possible warm up time.

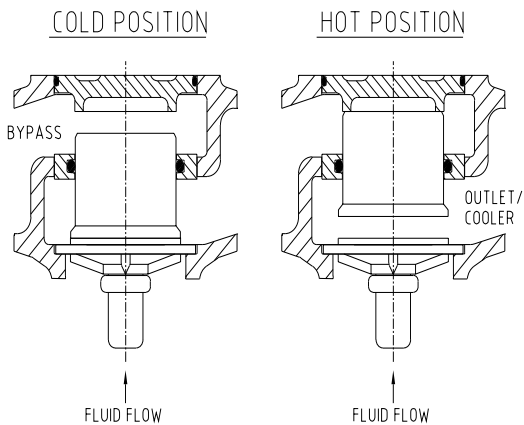

Operation and flow control is established by the temperature element, which constantly monitors and regulates the process fluid to the exact specified temperature setting.

When required the valve will positively shut off the bypass line to give full cooling.

A 3-way valve ensures constant volume flow in the system and gives no restriction during the warm up cycle, ensuring maximum performance. Where shut off is not required, bypass holes are available.

The temperature control power is created by the expansion of a wax/copper mixture which is highly sensitive to temperature changes.

Large forces are created by the warming/expansion of the mixture which in turn acts upon the sliding valve, thus regulating the flow.

The diagram opposite shows the valve actuation in diverting mode at start and cooling positions.

During operation the sliding valve constantly modulates for accurate temperature control.

The reliable rugged construction provides a unit sensitive to temperature variations, not easily disturbed by pressure changes and sudden surges, which maintains stable temperatures over a wide range of operating conditions.

Housing materials

- Cast Steel

Seal materials

- Buna N/Nitrile
- Viton
- Neoprene

Element materials

- Electroless nickel, plated brass and bronze
- Brass/bronze

Leakholes

In some applications, it is necessary to have leak holes drilled in the element to ensure a small flow between ports B and C. Leakholes are available in sizes ranging from 2 mm - 8 mm ($\frac{5}{64}$ " - $\frac{5}{16}$ ").

Temperature settings

A wide selection of element materials, seals and temperatures are available. Follow the equipment manufacturers' guidelines for oil systems and for specific operating temperatures of cooling/heating systems.

Temperature settings are available from 35°C - 82°C (95°F - 180°F). Refer to the temperature and element characteristics table on page 7 for specific temperature settings. In general the temperature quoted is the nominal operating temperature in diverting mode on water systems.

Please refer to the Leakhole size (G) section of the valve selection table on page 8 to determine the hole size required for specific applications.

For long life, AMOT valves should not be operated continuously at temperatures in excess of 14°C (25°F) of their maximum continuous rating. If this condition is anticipated then consult AMOT for suitable alternatives.

For mixing and oil circuits the temperature may be one to two degrees higher due to flow, viscosity and other system parameters.

Elements and seals are available in a variety of materials. These materials are suitable for most applications. Please contact AMOT for material compatibility information.

Thermostatic Control Valve - Model R

Applications

Diverting Applications

When valves are used for diverting services, the inlet is Port A (temperature sensing port), with Port C being connected to the cooler, and Port B connected to the cooler by-pass line.

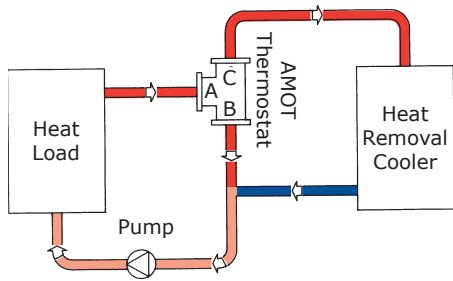

Mixing Applications

When valves are used for mixing service, Port C is the cold fluid inlet port from the cooler, Port B is the hot by-pass fluid inlet, and Port A the common outlet. Port A is the temperature sensing port and will mix the hot and cold fluids in the correct proportion so as to produce the desired outlet temperature leaving Port A.

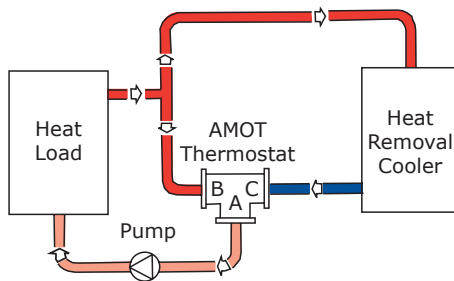

2-Way Water Saving Applications

Valve as shown maintains minimum flow through cooler to conserve water. Requires internal leak hole to permit small flow for sensing.

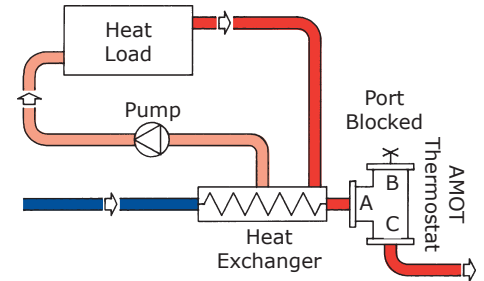

Valve Characteristics

Pressure drop (Metric units)

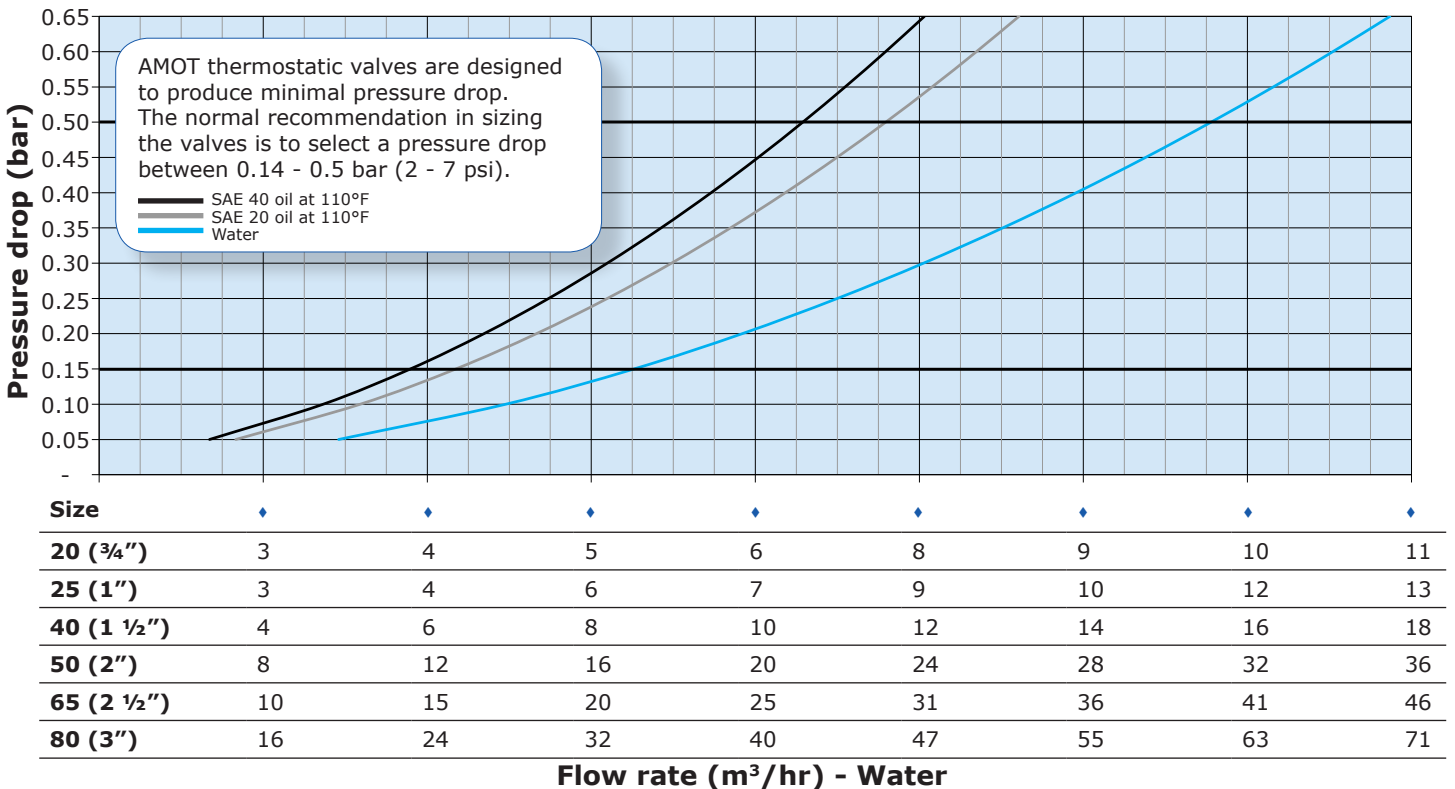

Thermostatic Control Valve - Model R

Valve Characteristics Continued

Pressure drop (English units)

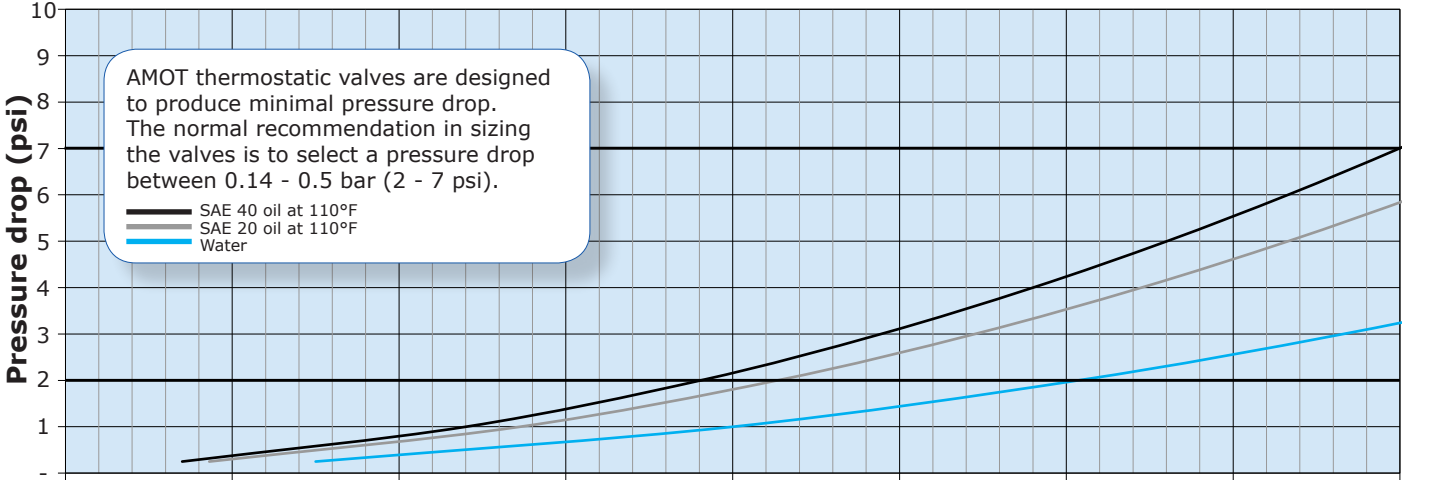

Size	6	10	13	16	19	22	26	29
20 (¾")	6	10	13	16	19	22	26	29
25 (1")	7	11	14	18	22	25	29	32
40 (1 ½")	10	15	20	25	30	35	40	45
50 (2")	20	31	41	51	61	71	82	92
65 (2 ½")	26	39	52	65	78	91	104	117
80 (3")	40	61	81	101	121	141	162	182

Flow rate (US gpm) - Water

Flow coefficient

Flow coefficient (calculated)		
Size	Kv	Cv
20 (¾")	14	16
25 (1")	16	18
40 (1 ½")	22	25
50 (2")	44	51
65 (2 ½")	56	65
80 (3")	87	101

$Kv = 0.865 Cv$

$Cv = 1.156 Kv$

Kv is the flow coefficient in metric units. It is defined as the flow rate in cubic meters per hour (m³/hr) of water at a temperature of 16° Celsius with a pressure drop across the valve of 1 bar. The basic formula to find a valve's Kv is shown below:

$$Kv = Q \sqrt{\frac{SG}{DP}} \quad Q = Kv \sqrt{\frac{DP}{SG}} \quad DP = \left[\frac{Q}{Kv} \right]^2 SG$$

Q = Flow in m³/hr
 DP = Pressure drop (bar)
 SG = Specific gravity of fluid (Water = 1.0)
 Kv = Valve flow coefficient (Metric units)

Cv is the imperial coefficient. It is defined as the flow rate in US Gallons per minute (gpm) of water at a temperature of 60° Fahrenheit with a pressure drop across the valve of 1 psi. The basic formula to find a valve's Cv is shown below:

$$Cv = Q \sqrt{\frac{SG}{DP}} \quad Q = Cv \sqrt{\frac{DP}{SG}} \quad DP = \left[\frac{Q}{Cv} \right]^2 SG$$

Q = Flow in US Gallons/Min
 DP = Pressure drop (psi)
 SG = Specific gravity of fluid (Water = 1.0)
 Cv = Valve flow coefficient (English units)

Thermostatic Control Valve - Model R

Valve Characteristics Continued

Viscosity correction

For the selection of valves for use with more viscous fluids than water, the following must be calculated in addition to using the previously mentioned formulae:

- Viscosity

Find the viscosity of the fluid to be used in the valve. This will generally be in centistokes (cST).

ISO grade oil is easy to calculate as the grade no. is the viscosity.

I.e. ISO VG 46 = 46 centistokes at 43°C (110°F)

- Viscosity correction

Once the viscosity value has been found, the flow coefficient correction factor can be established using the viscosity correction graph below.

The correction value (Fv) that is produced by the graph should then be multiplied by the original flow coefficient. This gives the corrected flow coefficient, which can then be used in the standard formula.

e.g.:

100 cST = correction factor of 0.68

0.68 x flow co. = corrected flow co. (Kv or Cv)

Viscosity correction curve (Fv)

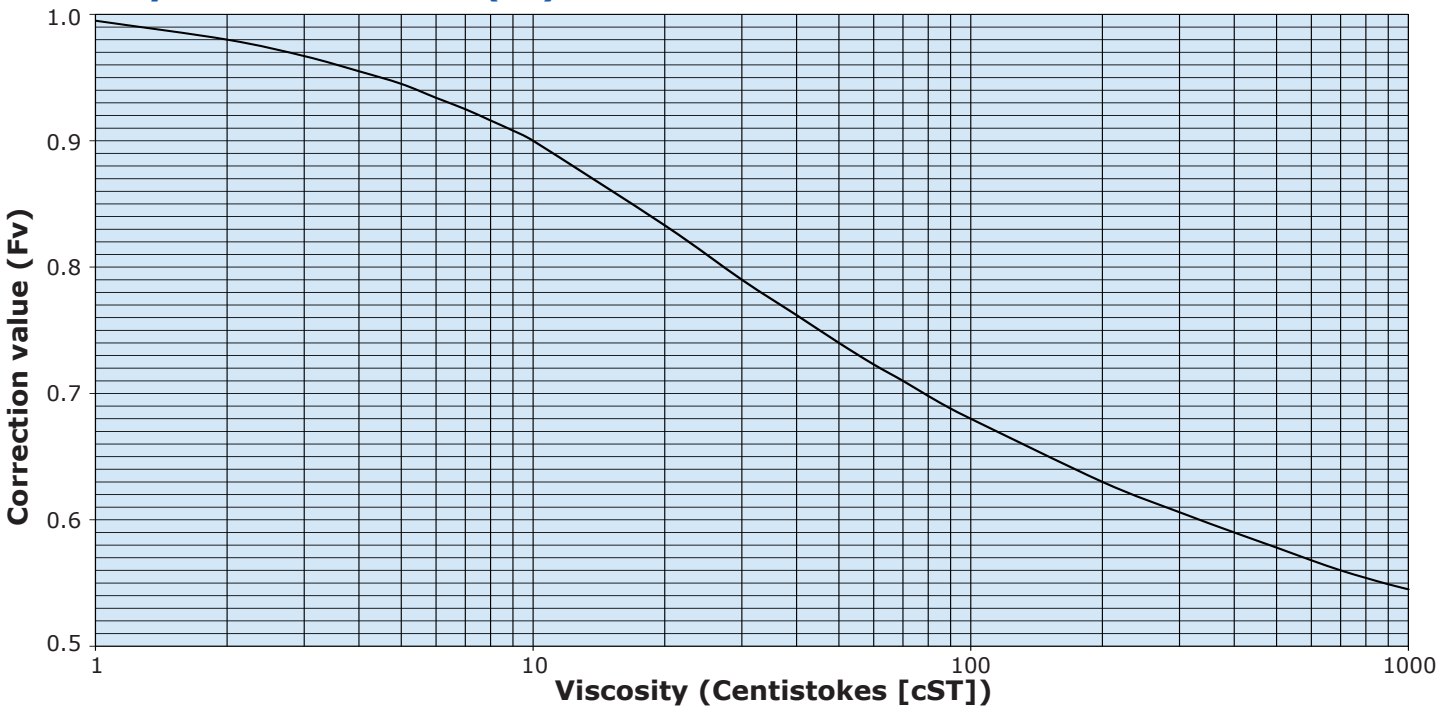

SAE oils viscosities

Engine oils	
Oil	cST
SAE 5W	6.8
SAE 10W	32
SAE 20	46
SAE 20W	68
SAE 30	100
SAE 40	150
SAE 50	220
6 B	394
8 B	571

Gear oils	
Oil	cST
SAE 75W	22
SAE 80W	46
SAE 85W	100
SAE 90	150
SAE 140	460

Approximate viscosities of SAE oils at 43°C (110°F) (cST).

Based on leading oil manufacturers' published data.

Thermostatic Control Valve - Model R

Valve Characteristics Continued

Available versions

Valve size (B) - mm (inches)	Port connection (D)		
	Butt Weld DIN 2448 PN40 (X)	Socket Weld ANSI B16.11 (Y)	Butt Weld ANSI B36.10 SCH.40 (Z)
20 (¾")	✓	✓	✓
25 (1")	✓	✓	✓
40 (1 ½")	✓	✓	✓
50 (2")	✓	✓	✓
65 (2 ½")	✓	✓	
80 (3")	✓		

Temperature and element characteristics

Code	Control temp.		Temperature range				Max temp. cont.			
			20 - 40 mm (¾" - 1 ½")		50 - 80 mm (2" - 3")		20 - 40 mm (¾" - 1 ½")		50 - 80 mm (2" - 3")	
	°C	°F	°C	°F	°C	°F	°C	°F	°C	°F
095	35	95	30-40	86-104	29-41	84-105	50	122	49	120
100	38	100	33-42	91-108	34-42	93-108	75	167	50	122
110	43	110	38-47	100-117	38-47	100-117	82	180	56	133
120	49	120	43-55	109-131	43-54	109-129	88	191	66	150
130	54	130	49-60	120-140	51-60	124-140	95	203	68	158
140	60	140	54-65	129-149	57-66	135-151	99	210	74	165
150	66	150	60-71	140-160	63-72	145-162	100	212	82	180
160	71	160	65-76	149-169	68-78	154-172	100	212	88	190
170	77	170	73-82	163-180	74-83	165-181	100	212	93	200
175	79	175	77-85	171-185	77-85	171-185	105	221	102	215
180	82	180	79-88	174-190	79-88	174-190	110	231	104	220

Element type and seal material

Code	Element type				Element construction	Seal material
	RO20 - 40	RO50 - 65		RO80		
		USA/Canada	Europe/Asia-PAC			
01	5435X	21376X	46856X	1096X	Standard	Buna N/Nitrile
02						Viton
03						Neoprene
04	5435P	21376P	46856P	1096P	Electroless nickel	Buna N/Nitrile
05						Viton
06						Neoprene

Thermostatic Control Valve - Model R

How to Order

Use the table below to select the unique specification of your Model R Thermostatic Control Valve.

Example	RO	40	S	X	110	03	4	-AA	Code description	Comments
									Valve model (A)	
Valve model (A)	RO								Standard	
									Valve size (B) - mm (inches)	
Valve size (B)		20							20 (¾")	1 Element
		25							25 (1")	1 Element
		40							40 (1 ½")	1 Element
		50							50 (2")	1 Element
		65							65 (2 ½")	1 Element
		80							80 (3")	2 Elements
									Body Material (C)	
Body material (C)			S						Cast steel	
									Port connection (D)	
Port connection (D)				X					Butt Weld DIN 2448 PN40	20-80 mm
				Y					Socket Weld ANSI 16.11	20-65 mm
				Z					Butt Weld ANSI B36.10 SCH.40	20-50 mm
									Control temperature °F (E)	
Control temperature °F (E)				*					For temperatures available, refer to the temperature and element characteristics table on page 7.	
									Element and seal material (F)	
Element and seal material (F)							**		For element/seal materials available, refer to the element type and seal material table on page 7.	
									Leakhole size (G) - mm (inches)	
									Leakhole diameter between ports B & C	
Leakhole size (G)								0	None	
								2	2 (5/64")	
								3	3 (1/8")	
								4	4 (5/32")	
								5	5 (13/64")	
								6	6 (1/4")	
								8	8 (5/16")	
									Customer special requirements (H)	
Customer special requirements (H)									Standard	
								-***	Customer special code	

Thermostatic Control Valve - Model R

Specification

		Metric units	English units
Flow rate		3 - 82 m ³ /hr	13 - 360 gpm
Body material	Cast steel BS 3146 CLA 1A-ASTM A216 WCB-DIN 17245 Grade 1.0169 (GSC 25N)		
Seal materials	Buna N/Nitrile, Viton, and Neoprene		
Mounting position	Any orientation		
Welded port connections	Butt Weld DIN 2448 PN40	20 - 80 mm	¾" - 3"
	Butt Weld ANSI B36.10 SCH.40	20 - 50 mm	¾" - 2"
	Socket Weld ANSI B16.11	20 - 65 mm	¾" - 2 ½"
Valve sizes (nominal bore)		20 - 80 mm	¾" - 3"
Recommended pressure drop		0.14 - 0.5 bar	2 - 7 psi
Control temperatures		35°C - 82°C	95°F - 180°F
Maximum working pressure		35 bar	500 psi
Accreditations available	PED	Suitable for Group 1 & 2 liquids. Ensure materials are compatible.	
	ATEX	 II 2G TX X	
	CE	Complies with all relevant EU directives	

Weights

Approximate weights in kg (lbs)

Port connection (D)	Valve size (B) - mm (inches)					
	20 (¾")	25 (1")	40 (1 ½")	50 (2")	65 (2 ½")	80 (3")
Butt Weld DIN 2448 PN40 (X)	3.2 (7)	3.2 (7)	3.5 (8)	7 (15)	7 (15)	17.5 (39)
Socket Weld ANSI B16.11 (Y)	3.5 (8)	3.5 (8)	4 (9)	7.5 (16)	7.5 (16)	N/A
Butt Weld ANSI B36.10 SCH.40 (Z)	3.2 (7)	3.2 (7)	3.5 (8)	7 (15)	N/A	N/A

Thermostatic Control Valve - Model R

Valve Dimensions

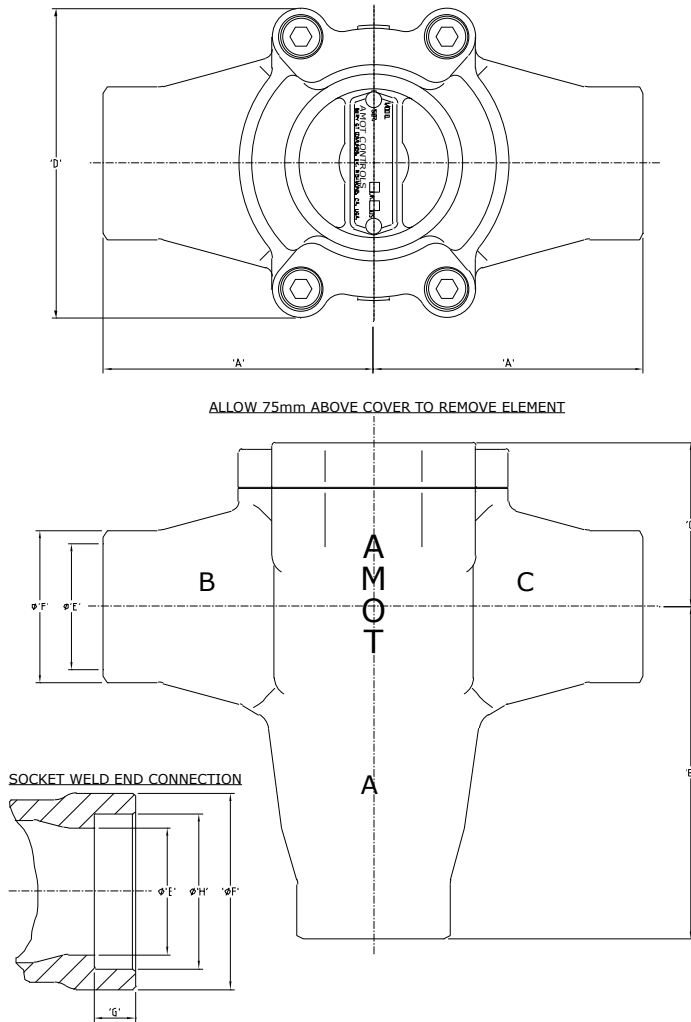

Dimensions - mm (inches)

General dimensions				
Dimensions	Nominal bore size			
	20 - 40 mm ($\frac{3}{4}$ " - 1 $\frac{1}{2}$ ")		50 - 80 mm (2" - 3")	
	Butt	Socket	Butt	Socket
A	85 (3.35")	95 (3.74")	100 (3.94")	110 (4.33")
B	105 (4.13")	115 (4.53")	132 (5.20")	142 (5.59")
C	52 (2.05")	52 (2.05")	64 (2.52")	64 (2.52")
D	102 (4.02")	102 (4.02")	123 (4.84")	123 (4.84")

Butt Weld DIN 2448 PN40 (X)						
	Nominal bore size mm (inches)					
	20 ($\frac{3}{4}$ ")	25 (1")	40 (1 $\frac{1}{2}$ ")	50 (2")	65 (2 $\frac{1}{2}$ ")	80 (3")
ØE	22.3 (0.88")	28.5 (1.12")	43.1 (1.70")	54.5 (2.15")	70.3 (2.77")	78 (3.07")
ØF	27 (1.06")	34 (1.34")	48 (1.89")	60 (2.36")	76 (2.99")	89 (3.50")

Socket Weld ANSI B16.11 (Y)						
	Nominal bore size mm (inches)					
	20 ($\frac{3}{4}$ ")	25 (1")	40 (1 $\frac{1}{2}$ ")	50 (2")	65 (2 $\frac{1}{2}$ ")	80 (3")
ØE	20 (0.75")	25 (1.00")	40 (1.50")	50 (2.00")	65 (2.50")	N/A
ØF	38 (1.50")	46 (1.81")	62 (2.44")	74 (2.91")	92 (3.62")	N/A
G	13 (0.51")	13 (0.51")	13 (0.51")	16 (0.63")	16 (0.63")	N/A
ØH	27.2 (1.07")	33.9 (1.33")	48.8 (1.92")	61.2 (2.41")	74 (2.91")	N/A

Butt Weld ANSI B36.10 SCH.40 (Z)						
	Nominal bore size mm (inches)					
	20 ($\frac{3}{4}$ ")	25 (1")	40 (1 $\frac{1}{2}$ ")	50 (2")	65 (2 $\frac{1}{2}$ ")	80 (3")
ØE	20.9 (0.82")	26.6 (1.05")	40.9 (1.61")	52.5 (2.07")	N/A	N/A
ØF	27 (1.06")	34 (1.34")	48 (1.89")	60 (2.36")	N/A	N/A

Thermostatic Control Valve - Model R

Maintenance and Service Parts

Over time, exposure to foreign chemicals and particulate matter as well as prolonged operation at extreme conditions may reduce the effectiveness of the control valve. At such time, AMOT Thermostatic Valves can be restored to original performance by installing an AMOT thermostatic valve service kit or a seal kit and new temperature element.

Service kits are ONLY available for purchase from the Americas and Canada locations. If ordering from the Europe or Asia-PAC locations please purchase a seal kit and element to properly service your valve.

Service kits include all new seals and thermostatic element required for normal maintenance. Seal kits include new seals only. Whenever elements are replaced, the seals should also be replaced.

Ordering from Americas and Canada Service kits

Service kits are ONLY available for purchase from the Americas and Canada locations.

Service kits are available with element and seals required to service the valve. Order service kits using the AMOT valve part number and nominal temperature setting. Refer to the AMOT valve part number that is printed on the valve nameplate and the AMOT valve part number structure on page 8. The nominal temperature setting is also stamped onto the element flange.

Service kit model number structure

- 1) Replace Body material (C) and Port connection (D) with "KIT-".
- 2) If Special (H) is not blank, please contact the facility.

Ordering from Europe and Asia-PAC Seal kits

Seal kits are available with seals only. Order seal kits using the basic seal kit model number, valve size, and element/seal material code from the AMOT valve part number. Refer to the AMOT valve part number that is printed on the valve nameplate and the AMOT valve part number structure on page 8.

AMOT recommends fully servicing thermostatic control valves with each regularly scheduled major overhaul of the turbine, engine, compressor or other associated equipment. AMOT recommends a service interval of not more than 24 months to ensure optimum valve performance.

AMOT designs and tests all its products to ensure that high quality standards are met. For good product life, carefully follow AMOT's installation and maintenance instructions; failure to do so could result in damage to the equipment being protected or controlled. Thermostatic service kits may also be used for adapting valves to new service temperatures. Please request a new nameplate when adapting valves to a new service temperature by contacting the facility.

AMOT does NOT offer service kits for 3" RO (RO80) Model R Thermostatic Valves. In order to properly service a 3" RO valve please purchase an element and seal kit. Refer to the ordering instructions on page 12.

Example valve part number							
A	B	C	D	E	F	G	H
RO	25	S	X	120	01	0	
Example service kit model number							
A	B	C	D	E	F	G	H
RO	25	KIT-		120	01	0	

A - Valve model
B - Valve size
C - Body material
D - Port connection
E - Control temperature (°F)
F - Element and seal material
G - Leakhole size
H - Special

Element(s)

Order temperature elements using the element part number which is identified by the valve size, element/seal material code and nominal temperature setting from the AMOT valve part number. Refer to the AMOT valve part number that is printed on the valve nameplate and the AMOT valve part number structure on page 8.

Thermostatic Control Valve - Model R

Maintenance and Service Parts Continued

Ordering from Europe and Asia-PAC continued

Seal kit model number structure

- 1) Identify the valve size, located in the Valve size (B) section of the AMOT valve part number. Use that value to identify the corresponding basic model number in Table 1.
- 2) Identify the element/seal material code, located in the Element and seal material (F) section of the AMOT valve part number. Use that value to identify the corresponding seal code in Table 2.
- 3) Place the seal code after "X1" in the basic model number to complete the seal kit model number, as shown in Table 3.

Basic model no.	Valve size (B) ¹
46857X1	20, 25, 40
46858X1	50, 65
80660X1	80

Seal code	Element/seal material (F) ²
01	01, 04
02	02, 05
03	03, 06

	Basic model no. (Table 1)	Seal code (Table 2)
	46857X1	01, 02, 03
	46858X1	
	80660X1	
Examples		
Valve part number	Seal kit model number	
RO25SX120010	46857X1	01
RO65SY130060	46858X1	03
RO80SZ130050	80660X1	02

Element part number structure

- 1) Identify the valve size, located in the Valve size (B) section of the AMOT valve part number. Two examples are shown in Table 4.
- 2) Identify the element/seal material code, located in the Element and seal material (F) section of the AMOT valve part number.
- 3) Identify the temperature, located in the Control temperature °F (E) section of the AMOT valve part number.
- 4) Use those 3 codes in Table 4 to identify the proper element part number.

	Valve size (B) ¹			Temperature °F (E)	Element/seal material (F) ²	Element part number	Qty.	Comments	
	20, 25, 40			095-180	01, 02, 03	5435X(Temp.)	1		
	50, 65					21376X(Temp.)		USA/Canada ONLY	
	80					46856X(Temp.)		Europe/Asia-PAC ONLY	
	20, 25, 40				04, 05, 06	1096X(Temp.)	2		
	50, 65					5435P(Temp.)		1	USA/Canada ONLY
	80					21376P(Temp.)			Europe/Asia-PAC ONLY
						46856P(Temp.)	2		
						1096P(Temp.)			
Examples									
Valve part number						Element part number	Qty.	Comments	
RO	50	S	X	095	06	0	46856P095	1	
RO	80	S	X	150	03	0	1096X150	2	

NOTES:

¹ If your valve size code does not correspond with the given values, please contact the facility to confirm your valve size code.

² If your element/seal material code does not correspond with the given values, please contact the facility to confirm your element/seal material code.

Thermostatic Control Valve - Model R

Maintenance and Service Parts Continued

Service parts

Service kit parts		
Ref no.	Qty.	Description
	RO20 - 65	
3	1	Element
4	1	Sleeve seal
5	1	Element seal

Seal kit parts			
Ref no.	Qty.		Description
	46857X1(--)/46858X1(--)	80660X1(--)	
4	1	2	Sleeve seal
5	1	2	Element seal

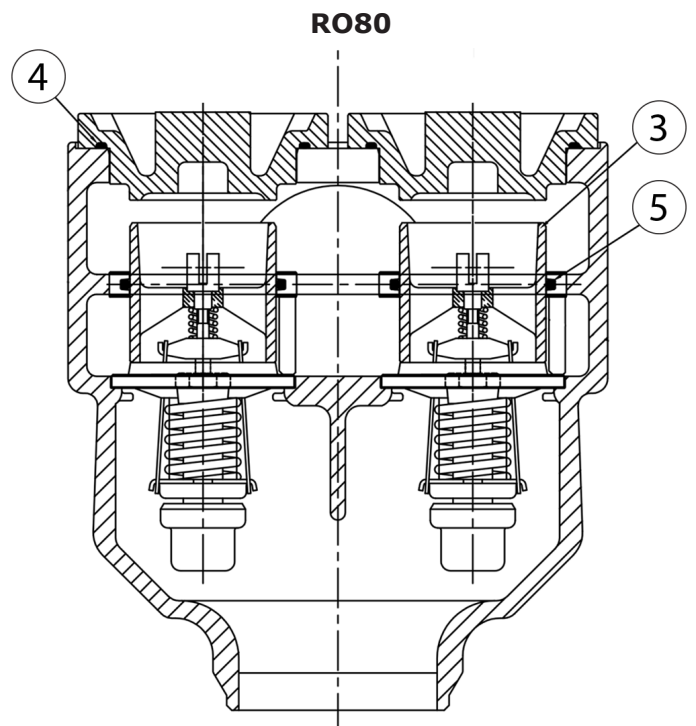
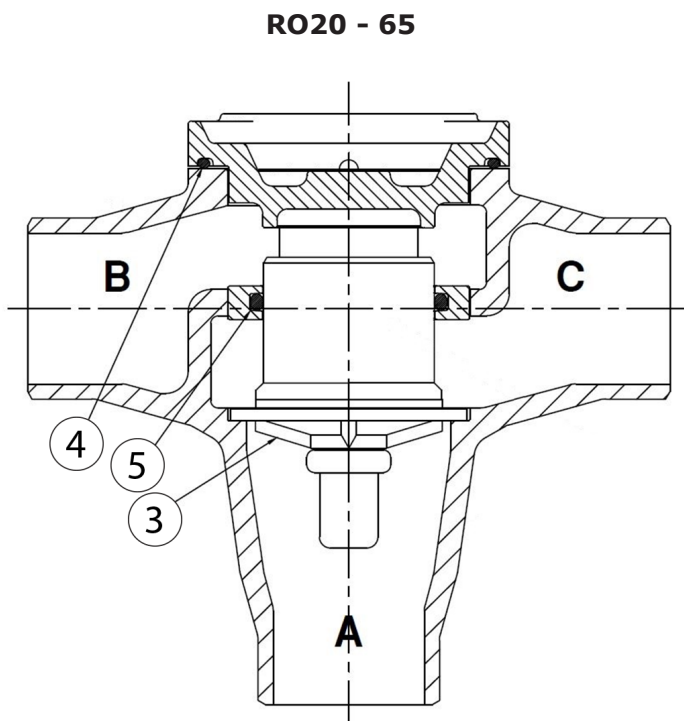

Thermostatic Control Valve - Model R

Contact

Americas

AMOT USA
8824 Fallbrook Dr.
Houston, TX 77064
USA

Tel: +1 (281) 940 1800
Fax: +1 (713) 559 9419
Email: customer.service@amot.com

Asia Pacific

AMOT Shanghai
Bd. 7A, No. 568, Longpan Rd., Malu Jiading
Shanghai 201801
China

Tel: +86 21 5910 4052
Fax: +86 21 5237 8560
Email: shanghai@amot.com

Europe, Middle East and Africa

AMOT UK
Western Way
Bury St. Edmunds
Suffolk, IP33 3SZ
England

Tel: +44 1284 715739
Fax: +44 1284 760256
Email: info@amot.com

AMOT Germany
Rondenbarg 25
22525 Hamburg
Germany

Tel: +49 40 8537 1298
Fax: +49 40 8537 1331
Email: germany@amot.com